

# Original MINI Accessories. Installation Instructions.



## **Park Distance Control (PDC) Rear Retrofit** **MINI ONE and COOPER (R50)** **MINI COOPER S (R53)**

**Installation instructions only valid for U.S. cars.**

**Retrofit kit No.**            66 21 0 397 618    Park Distance Control (PDC) Rear Retrofit

### **Installation time**

The installation time is 2.0 hours, but this may vary depending on the condition of the car and the equipment in it.

### **Important information**

These installation instructions are primarily designed for use within the MINI dealership organisation and by authorised BMW service companies.

In any event the target group for these installation instructions is specialist personnel trained on MINI cars with the appropriate specialist knowledge.

All work must be completed using the latest MINI repair manuals, circuit diagrams, servicing manuals and work instructions in a rational order using the prescribed tools (special tools) and observing current health and safety regulations.

**To avoid unnecessary extra work and/or costs, if any installation or function problems occur, after a brief troubleshooting session (approx. 0.5 hours), contact the following:**

- 1. Either your national sales company or your regional office or**
- 2. The Support team via the Aftersales Assistance Portal (ASAP) using the optional technical parts support application.**

**Specify the chassis number and the part number of the installed retrofit kit and give a precise description of the problem.**

Do not archive the hard copy of these installation instructions since daily updates are made by ASAP.

See ASAP for details of the pictograms.

Pictograms



Denotes instructions that draw your attention to special features.

◀ Denotes the end of the instruction or other text.

Subject to technical modifications.

**Print out section 10 of these installation instructions and give it to the customer.**

**Installation information**

Ensure that the cables/lines are not kinked or damaged as you install them in the car. The costs incurred as a result of this will not be reimbursed by BMW AG.

Additional cables/lines that you install must be secured with cable ties.

If the specified PIN chambers are already used, bridges, double crimps or twin-lead terminals must be used.

**Special tools required**

None

## Contents

Section	Page
1. Parts list.....	4
2. Preparations.....	5
3. Connection diagram.....	6
4. Installation and cabling diagram.....	7
5. To install the license plate holder.....	8
6. To install the control unit and signal generator.....	9
7. To install and connect the wiring harness.....	10
8. Concluding work and coding.....	11
9. Circuit diagram.....	12
10. Customer information for operating the Rear Park Distance Control (PDC).....	14

# 1. Parts list

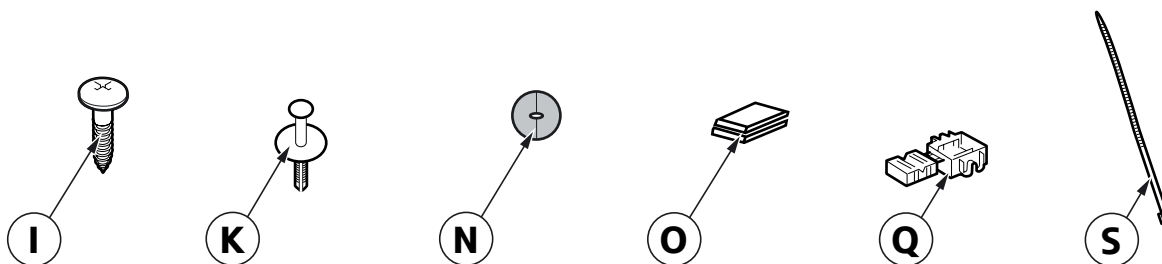
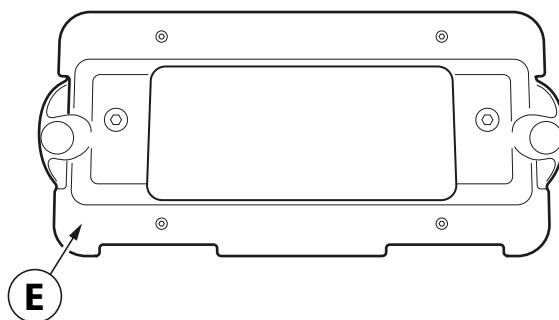
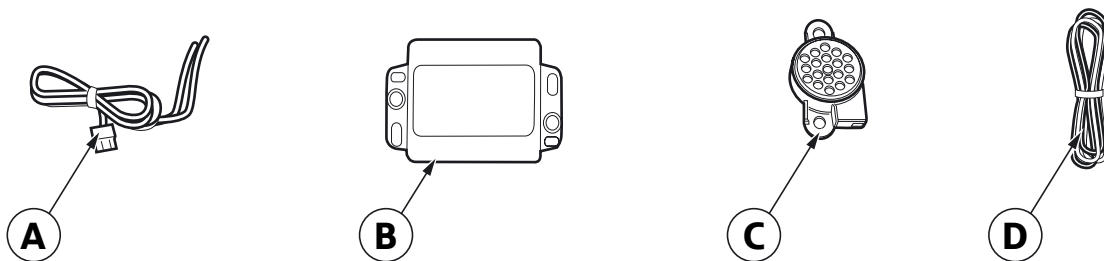

R50 1429 Z

## Legend

- |   |                                |   |                              |
|---|--------------------------------|---|------------------------------|
| A | Wiring harness                 | K | Expanding rivet 6 mm (4x)    |
| B | Control unit                   | N | 2-piece rubber grommet       |
| C | Signal generator               | O | Velcro strip (2x)            |
| D | Signal generator cable         | Q | Miniature connector (4x)     |
| E | License plate holder           | S | Cable tie 200 x 3.6 mm (20x) |
| I | Philips screw 4.8 x 15 mm (4x) |   |                              |

 The other parts in the universal retrofit kit are not required. ◀

## 2. Preparations

	<b>TIS No.</b>
Conduct a brief test	---
Disconnect negative pole of battery	12 00 ...
<b>The following components must be removed first of all</b>	
Trunk floor trim	51 47 101
Right trunk wheel arch trim	51 47 161
Trim for the tailgate	51 49 000

### 3. Connection diagram

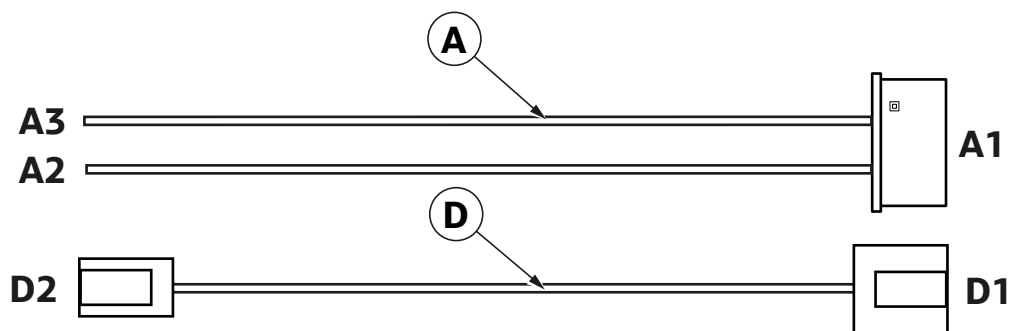

R52 0103 Z

Branch/Item	Designation	Signal	Cable color / Cross-section	Connection location in the car	Abbreviation / Slot
A	Wiring harness	---	---	---	---
A1	SW 4-pin socket casing	---	---	On control unit <b>B</b>	---
A2	Cable open	Terminal 31	SW 0.35 mm <sup>2</sup>	Using miniature connector <b>Q</b> on BR cable from joint connector terminal 31 on the right-hand side of the trunk	X494
A3	Cable open	RFS terminal	RT 0.35 mm <sup>2</sup>	Using miniature connector <b>Q</b> to BL/GE cable on the standard wiring harness on the right-hand side of the trunk	X318
D	Signal generator cable	---	---	---	---
D1	SW 4-pin socket casing	---	---	On control unit <b>B</b>	---
D2	SW 2-pin socket casing	---	---	On signal generator <b>C</b>	---

## 4. Installation and cabling diagram

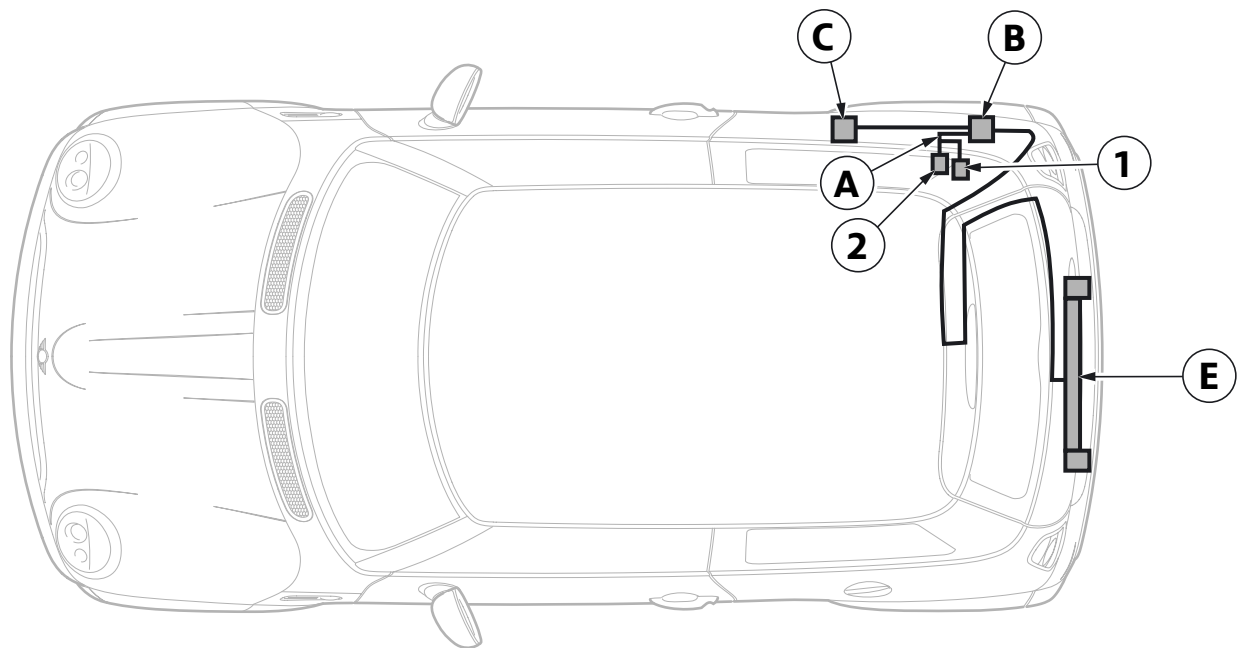

R50 1430 Z

### Legend

- A Wiring harness
- B Control unit
- C Signal generator
- E License plate holder

- 1 RFS terminal pick-up on the standard wiring harness
- 2 Terminal 31 tap on joint connector **X494**

## 5. To install the license plate holder

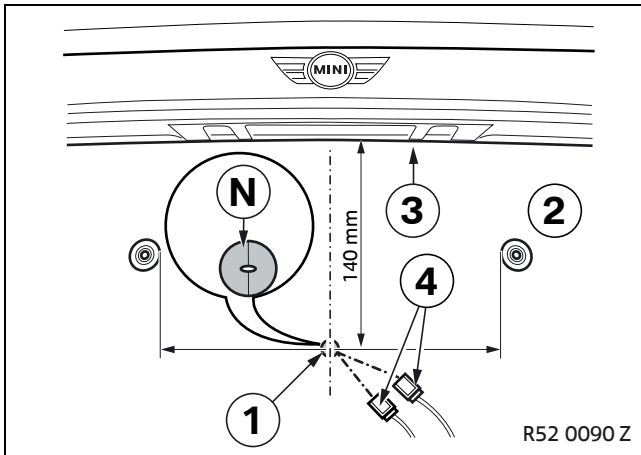

Mark the hole (1) on the trunk lid (2) as follows:

- In the middle
- Approx. 140 mm from the edge (3)

Drill through the trunk lid (2) at the marked position (1) using a 12 mm step drill bit.

Complete the anti-corrosion treatment process.

Route the sensor cable (4) through 2-piece rubber grommet **N** and insert 2-piece rubber grommet **N** into the trunk lid (2).

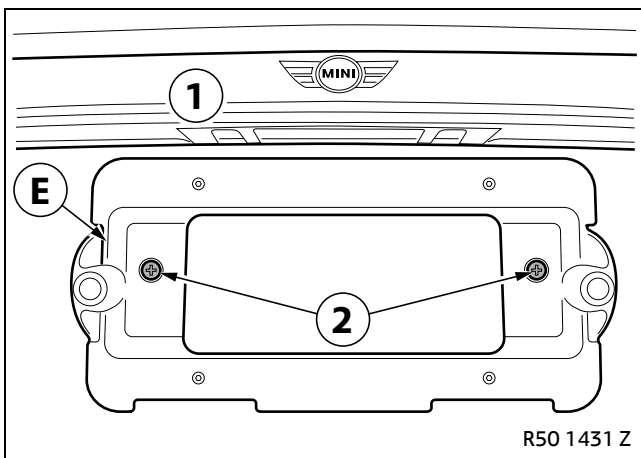

Secure license plate holder **E** to the trunk lid (1) using the license plate screws (2).

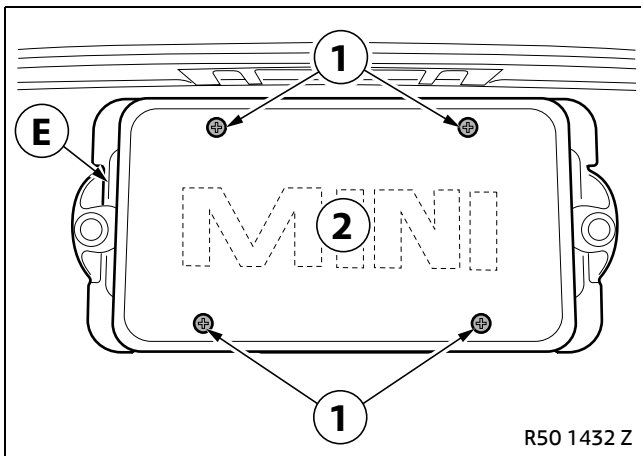

Secure the license plate (2) to license plate holder **E** using the license plate screws (1).



## 6. To install the control unit and signal generator

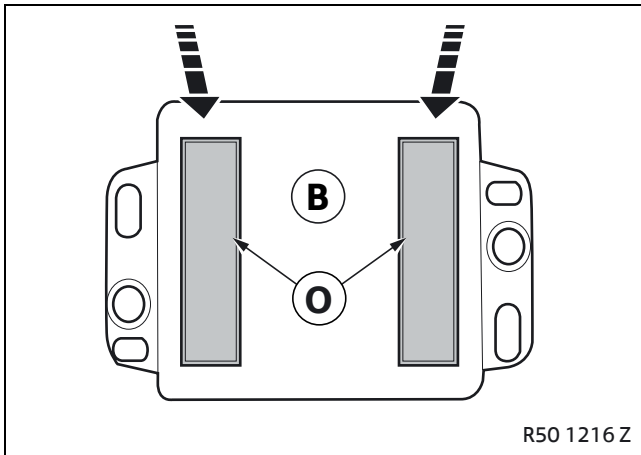

Clean and degrease the gluing surfaces.  
Affix Velcro strips **O** to control unit **B**.

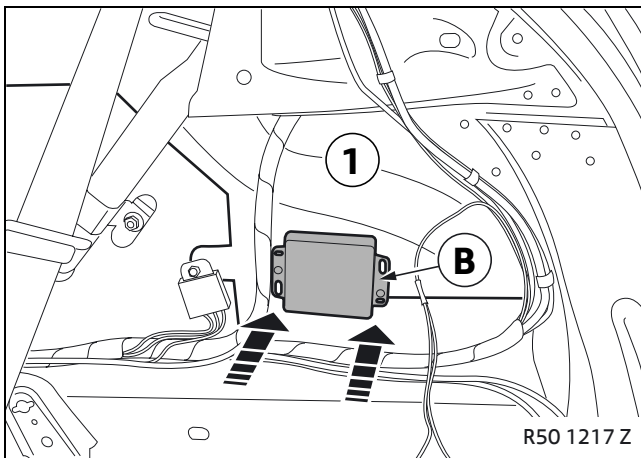

**Cars with harman/kardon hi-fi loudspeaker system (SA 674) only**

Remove the amplifier with holder.

**All cars**

Glue control unit **B** onto the right-hand body side part (1).

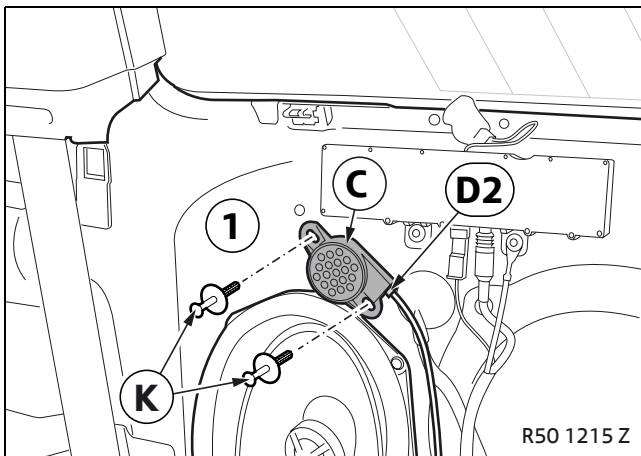

Place signal generator **C** on the right body side section (1) and mark the positions for the holes.

Drill the hole with a 6.0 mm twist drill bit and treat the area with anti-corrosive coating.

Use expanding rivets **K** to secure signal generator **C** to the right body side section (1).

Connect branch **D2** (SW 2-pin) to signal generator **C**.

## 7. To install and connect the wiring harness

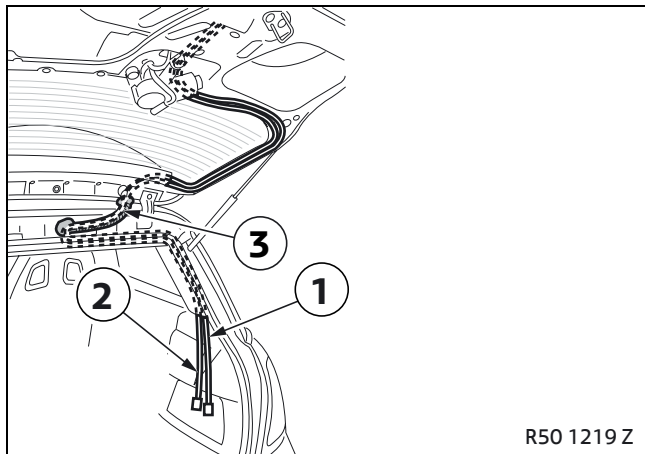

Route sensor cables (1) and (2) along the standard wiring harness through the grommet (3) and into the right-hand side of the trunk.

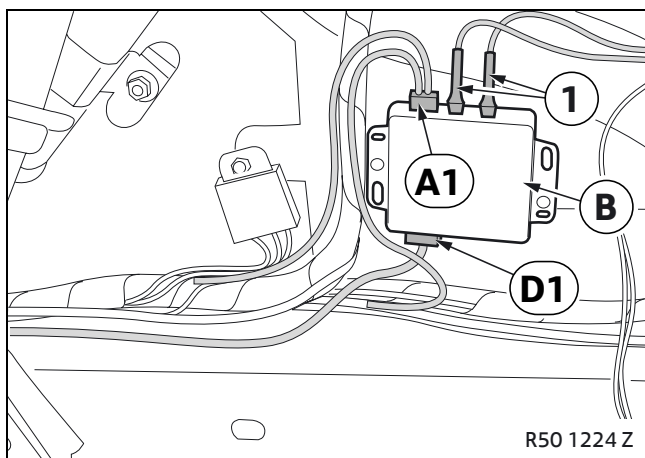

Connect the sensor cable (1), branch **A1** (SW 4-pin) and branch **D1** (SW 4-pin) to control unit **B**.

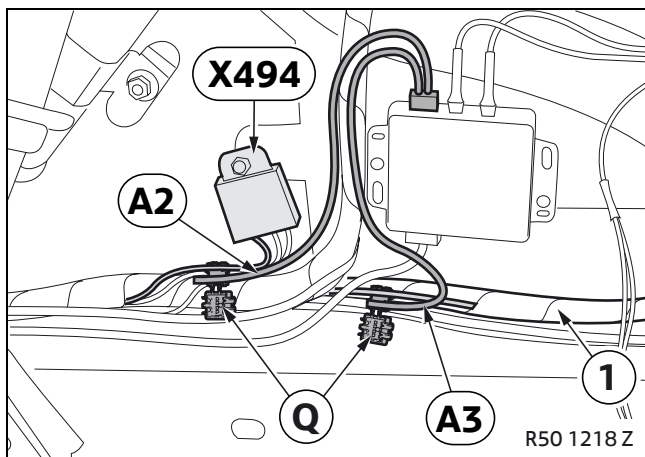

Route branch **A2**, SW cable, to joint connector **X494**, BR cable, and connect it with miniature connector **Q**.

Connect branch **A3**, RT cable, to the standard wiring harness (1) leading to the right tail light as follows:

- Select the BL/GE cable
- Check that the terminal RFS reversing signal is active
- Connect branch **A3** using miniature connector **Q**

## **8. Concluding work and coding**

This retrofit system does not require coding.

- Connect the battery
- Conduct a brief test
- Perform a function test of the PDC
- Re-assemble the car

## 9. Circuit diagram

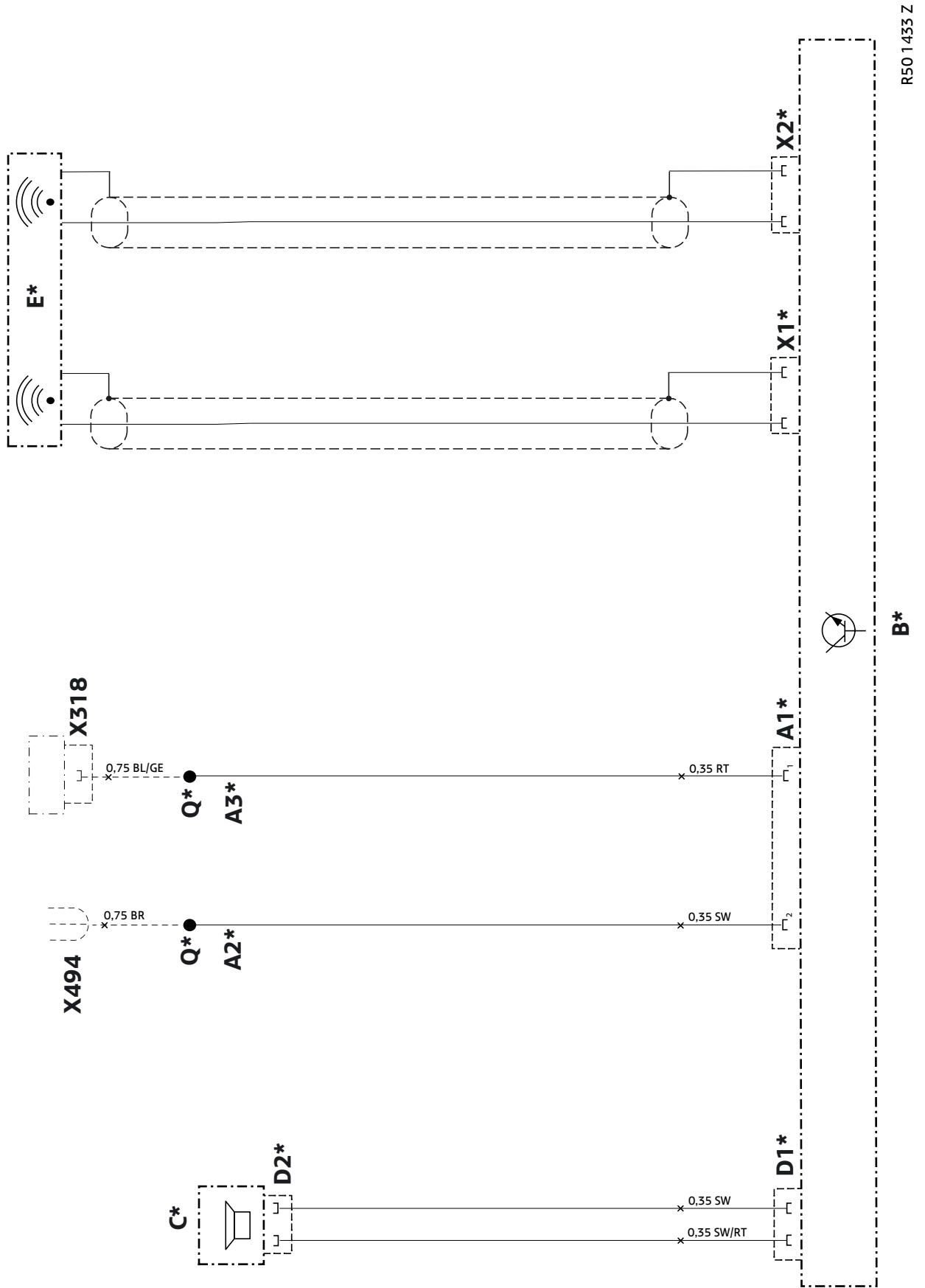

## 9. Circuit diagram

### Legend

<b>A1*</b>	SW 4-pin plug
<b>A2*</b>	Terminal 31 pick-up
<b>A3*</b>	Terminal RFS pick-up
<b>B*</b>	Control unit
<b>C*</b>	Signal generator
<b>D1*</b>	SW 4-pin plug
<b>D2*</b>	SW 2-pin plug
<b>E*</b>	License plate holder
<b>Q*</b>	Miniature connector
<b>X1*</b>	SW 2-pin plug
<b>X2*</b>	SW 2-pin plug
<b>X318</b>	SW 6-pin plug
<b>X494</b>	Terminal 31 joint connector

All the designations marked with an asterisk (\*) apply only to these installation instructions or this circuit diagram.

### Cable colors

BL	Blue
BR	Brown
GE	Yellow
RT	Red
SW	Black

## 10. Customer Information for Operating the Rear Park Distance Control (PDC)

**Print out this customer information and give it to the customer.**

Pictograms:



Denotes instructions that draw your attention to dangers.



Denotes instructions that draw your attention to special features.

◀ Denotes the end of the instruction or other text.

### Function

The PDC is a system which assists you when parking and maneuvering.

Ultrasonic sensors record the position of obstacles behind the car and inform the driver by means of acoustic signals.

Acoustic signals start when an obstacle is detected by the PDC.

The closer the car approaches the obstacle, the more rapid the acoustic signals. A permanent signal sounds when the distance to the obstacle reaches 30 cm/1 ft.

### Operation

The PDC is switched on automatically as soon as reverse gear is engaged when the ignition is turned on.

The PDC is switched off automatically as soon as the ignition is turned off or reverse gear is disengaged.



Judging obstacles is exclusively the responsibility of the driver, who must drive attentively and carefully in order to avoid damaging property and injuring people. ◀



As with all ultrasonic distance measuring systems, signals may be triggered incorrectly or individual objects may not be registered sufficiently.

Due to the car, blind spots may occur in front of the bumper and at its lateral ends. Obstacles in these blind spots may not be registered sufficiently, or not at all.

The limits of what can be physically measured may be reached when encountering very low obstacles (lower than 10 cm/0,33 ft), thin obstacles (thinner than 6 cm/0,2 ft) or pointed obstacles. Such obstacles might not be registered sufficiently under certain circumstances.

To guarantee that the PDC operates properly, you should drive slowly when parking and maneuvering and also keep the ultrasonic sensors free from snow, ice or dirt.

Strong wind, falling snow or rain can trigger incorrect signals. ◀